

READY HP SPRAY

Ready-to-use spray disinfectant containing hydrogen peroxide for surfaces

1000 ml



Product Specifications

* CHEMICAL COMPOSITION

Hydrogen peroxide, deionized water

* PRODUCT SPECIFICATIONS

It is a hydrogen peroxide based, anti-corrosive product which has a pleasant odor and used for the quick disinfection of medical device surfaces. Ready Hp Spray is a ready-to-use and highly efficient medical device disinfectant. Its formulation is based on hydrogen peroxide. It is a disinfectant which does not contain aldehyde, alcohol and phosphate and is anti-corrosive and material-resistant. It is dermatologically tested.

* AREAS OF USE

It is used for the cleaning and disinfection of all horizontal and vertical surfaces and especially PVC epoxy areas, floors, walls, ultrasonography probes, incubators, aerators and micromotor tips used in dentistry, stethoscopes, cabinets, doors, examination, disinfection requiring medical devices and equipment in ENT units as well as operating rooms, intense care rooms, sickbed edges, iv holders, microscopes, areas contacting with hands and skin and tools contacting with patients' skin in the hospitals that require quick disinfection.

* USE

Ready Hp Spray, is a ready-to-use spray disinfectant suitable for use on all horizontal and vertical surfaces. It is sprayed from a distance of 30cm-40cm. It is wiped with a clean cloth and allowed to dry.

* ANTI-MICROBIAL CHARACTERISTICS

Bactericide, Fungicide, Virucide, Mycobactericide, Tuberculocide, Sporicide

Product

Item.-no
Content

Ref:5595
1

Quality Features

ISO / EN

ISO / EN

ISO / EN

ISO / EN

ISO / EN

ISO / EN

Certification of Medical Device / Notified Body

CAS

EN14348

EN14476

EN13727 , EN 13697, EN17126

EN13624

EN16615, EN17387, EN13704

CE 2195, 93/42 EEC, Class IIa

7722-84-1

READY HP SPRAY

Ready-to-use spray disinfectant containing hydrogen peroxide for surfaces

1000 ml



Packing

Quantity Inner Packing	1
Quantity Outer Packing	16
Quantity Per Pallet	42
Product Units Per Pallet	672
Pallet Dimensions cm	120x80
LxWxH Outer Packing in mm	485 X 300 X 220
Volume in m ³ Outer Packing	0,04031 m ³
Gross Weight Outer Packing in KG	20,88 KG
Content Wight ml = gr.	915 gr.

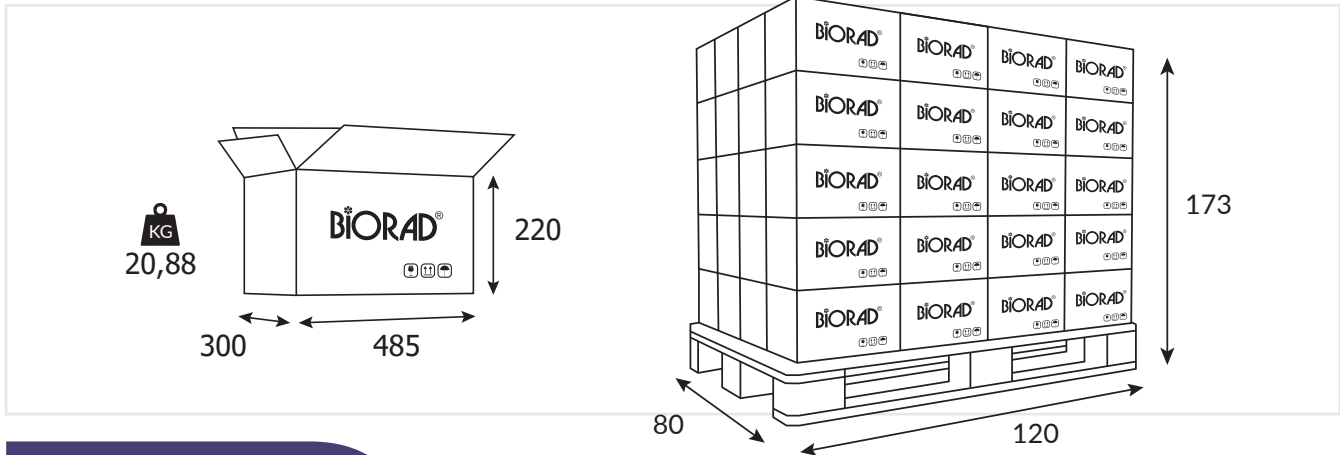

Labeling

HS Code	380894900019
Country of Origin	Türkiye
EAN Code Inner Packing	8699856754964
EAN Code Outer Packing	
Shelf Life	Two Years

Do you need more detailed information? We are happy to help!

The technical data are average production values and may vary slightly in individual cases. Subject to changes, no guarantee for printing errors or mistakes.